

Homework 3

Question 1

Reduce the block diagram shown below to a single transfer function, $T(s) = C(s)/R(s)$.

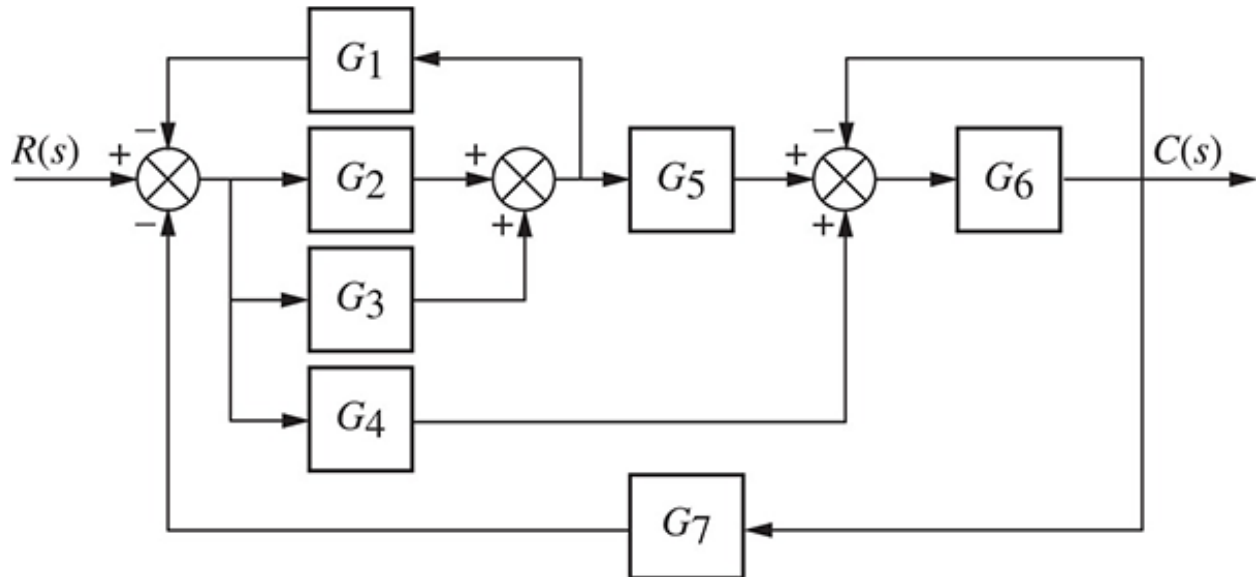

Solution

Combine the feedback with G_6 and combine the parallel G_2 and G_3 .

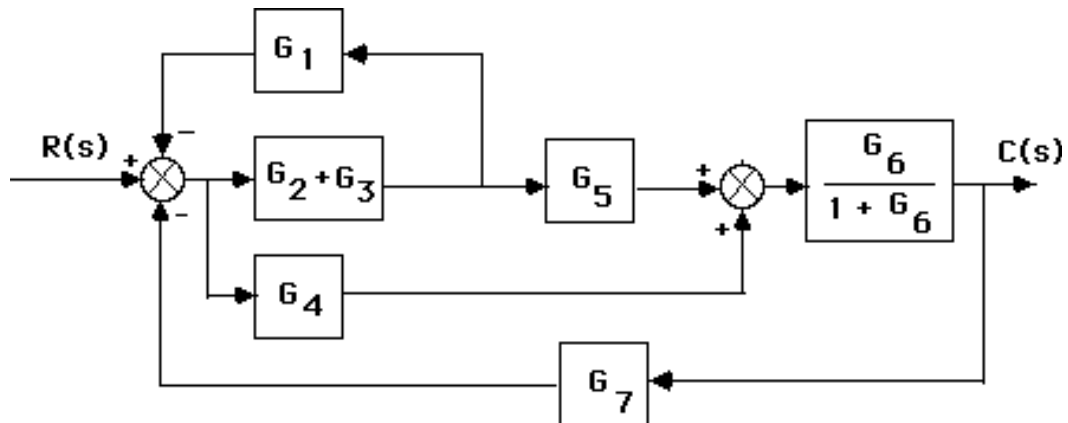

Move G_2+G_3 to the left past the pickoff point.

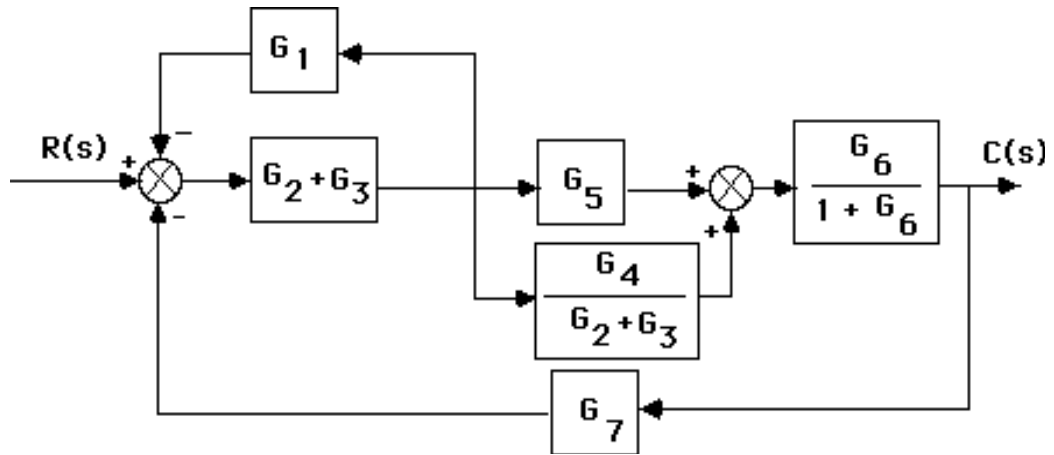

Combine feedback and parallel pair in the forward path yielding an equivalent forward-path transfer

function of

$$G_e(s) = \left(\frac{G_2+G_3}{1+G_1(G_2+G_3)} \right) \left(G_5 + \frac{G_4}{G_2+G_3} \right) \left(\frac{G_6}{1+G_6} \right)$$

But, $T(s) = \frac{G_e(s)}{1+G_e(s)G_7(s)}$. Thus,

$$T(s) = \frac{G_6 (G_4 + G_5 G_3 + G_5 G_2)}{G_6 (G_7 G_4 + G_7 G_5 G_3 + G_7 G_5 G_2 + G_3 G_1 + G_2 G_1 + 1) + G_1 (G_3 + G_2) + 1}$$

Question 2

A common application of dc motors is in accurate positioning of a mechanical load. A schematic diagram of a possible arrangement is shown in Figure below.

- Draw a suitable linear graph for the entire system shown in Figure below, mark the variables and parameters (you may introduce new, auxiliary variables but not new parameters), and orient the graph.
- Give the number of branches (b), nodes (n), and the independent loops (l) in the complete linear graph. What relationship do these three parameters satisfy? How many independent node equations, loop equations, and constitutive equations can be written for the system? Verify the sufficiency of these equations to solve the problem.
- Take current through the inductor (i_L), speed of rotation of the motor rotor (ω_r), torque transmitted through the load shaft (T_k), and speed of rotation of the load (ω_l) as the four state variables; the armature supply voltage $v_a(t)$ as the input variable; and the shaft torque T_k and the load speed ω_l as the output variables. Write the independent node equations, independent loop equations, and the constitutive equations for the complete linear graph. Clearly show the state-space shell.
- Eliminate the auxiliary variables and obtain a complete state-space model for the system, using the equations written in Part (c) above. Express the matrices \mathbf{A} , \mathbf{B} , \mathbf{C} , and \mathbf{D} of the state space model only in terms of the system parameters R_a , L_a , k_m , J_r , k_l , b_l , and J_l .

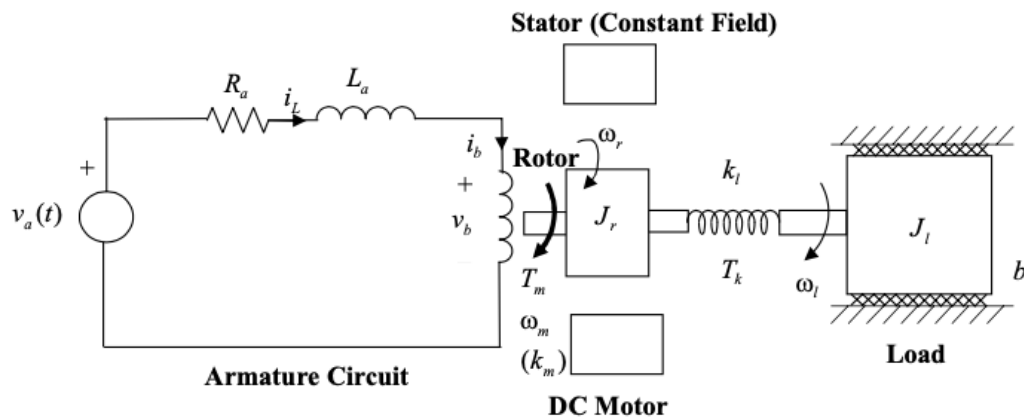

- (a) The complete linear graph is shown in Figure S4.11.

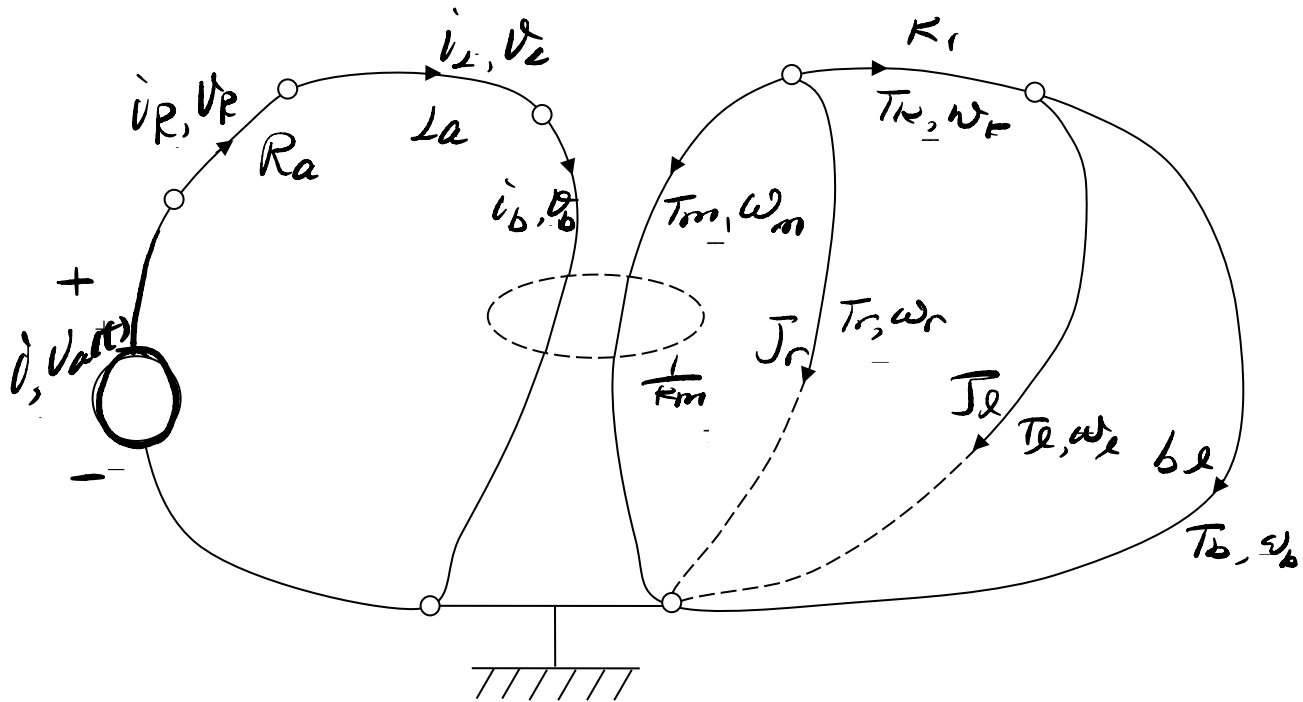

- (b) We have $b = 9$, $n = 6$, $l = 4$ for this linear graph. It satisfies the topological relationship $l = b - n + 1$. There will be 5 (i.e., $n-1$) node equations, 4 loop equations, and 8 (i.e., $b-s$ where $s=1$) constitutive equations; totaling 17 equations. There are 17 (i.e., $2b-s$) unknowns. Since the number of equations is equal to the number of unknowns, the system is solvable.

- (c) State vector $\mathbf{x} = [i_L, \omega_r, T_k, \omega_l]^T$; Input vector $\mathbf{u} = [v_a(t)]$

Independent Node Equations:

$$\begin{aligned} i - i_R &= 0 \\ i_R - i_L &= 0 \\ i_L - i_b &= 0 \\ -T_m - T_r - T_k &= 0 \\ T_k - T_l - T_b &= 0 \end{aligned}$$

Independent loop equations:

$$\begin{aligned}
-v_b - v_L - v_R + v_a(t) &= 0 \\
-\omega_r + \omega_m &= 0 \\
-\omega_l - \omega_k + \omega_r &= 0 \\
-\omega_b + \omega_l &= 0
\end{aligned}$$

Constitutive equations:

$$\left. \begin{aligned}
L_a \frac{di_L}{dt} &= v_L \\
J_r \frac{d\omega_r}{dt} &= T_r \\
\frac{dT_k}{dt} &= k_l \omega_k \\
J_l \frac{d\omega_l}{dt} &= T_l
\end{aligned} \right\} \text{State-space shell}$$

$$\left. \begin{aligned}
v_R &= R_a i_R \\
T_b &= b_l \omega_b
\end{aligned} \right\} \text{Constitutive equations for D-type elements}$$

$$\left. \begin{aligned}
\omega_m &= \frac{1}{k_m} v_b \\
T_m &= -k_m i_b
\end{aligned} \right\} \text{Electro-mechanical transformer}$$

Note that there are 17 unknown variables ($i, i_R, i_L, i_b, T_m, T_r, T_k, T_l, T_b, v_R, v_L, v_b, \omega_m, \omega_r, \omega_k, \omega_l, \omega_b$) and 17 equations.

(d) Eliminate the auxiliary variables from the state-space shell, by substitution:

$$v_L = v_a(t) - v_b - v_R = v_a(t) - k_m \omega_m - R_a i_R = v_a(t) - k_m \omega_r - R_a i_L$$

$$T_r = -T_m - T_k = k_m i_b - T_k = k_m i_L - T_k$$

$$\omega_k = \omega_r - \omega_l$$

$$T_l = T_k - T_b = T_k - b_l \omega_b = T_k - b_l \omega_l$$

Hence, we have the state-space equations:

